

SW SERIES TANK FLUSH VALVE

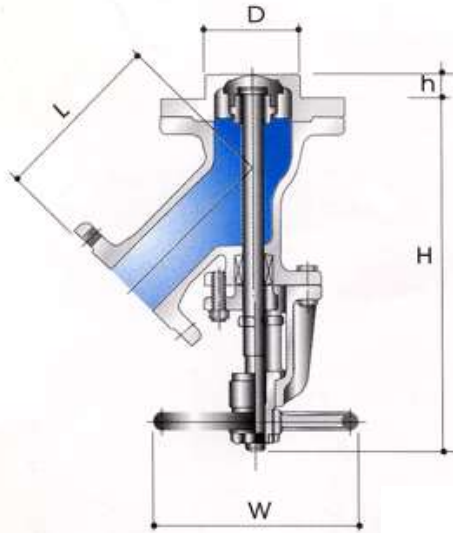

Lower Type



PARTS OF MATERIAL

No	PARTS NAME	MATERIAL
1	BODY	SCS 13, 14/CF8, 8M
2	FLANGE	SCS 13, 14/CF8, 8M
3	DISC	SCS 13, 14/CF8, 8M
4	YOKE	SCS 13, 14/CF8, 8M
5	STEM	STS 304, 316
6	SLEEVE	BRONZE
8	GLAND	SCS 13, 14/CF8, 8M
13	GUIDE	SCS 13, 14/CF8, 8M
14	GUIDE PIN	STS 304, 316
15	WHEEL NUT	BRONZE
16	HAND WHEEL	FCD
17	SET SCREW	STS 304
18	NAME PLATE	Al
19	PACKING	TEFLON
20	GASKET	TEFLON
23	DISC NUT	STS 304

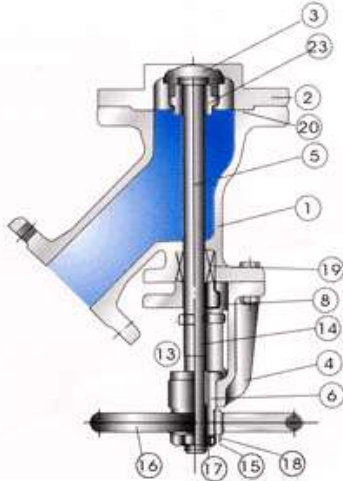

DIMENSION

10k-150LB

단위(mm)

SIZE (a×b)	1×1½	1×2	1½×2½	2×3	2½×4	3×5	4×6	5×8	6×8	8×10
L	115	115	140	160	170	220	230	250	290	340
H	320	320	340	350	400	430	510	650	670	800
W	155	155	170	200	200	230	270	300	350	400
h	30	30	38	45	50	65	75	90	100	115
D	50	50	75	90	115	135	165	200	235	250

SW SERIES TANK FLUSH VALVE



Upper Type

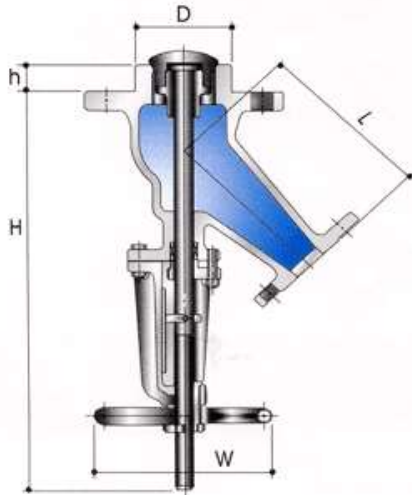

○ PARTS OF MATERIAL

No	PARTS NAME	MATERIAL
1	BODY	SCS 13, 14/CF8, 8M
2	FLANGE	SCS 13, 14/CF8, 8M
3	DISC	SCS 13, 14/CF8, 8M
4	YOKE	SCS 13, 14/CF8, 8M
5	STEM	STS 304, 316
6	SLEEVE	BRONZE
8	GLAND	SCS 13, 14/CF8, 8M
13	GUIDE	SCS 13, 14/CF8, 8M
14	GUIDE PIN	STS 304, 316
15	WHEEL NUT	BRONZE
16	HAND WHEEL	FCD
17	SET SCREW	STS 304
18	NAME PLATE	AI
19	PACKING	TEFLON
23	DISC NUT	STS 304

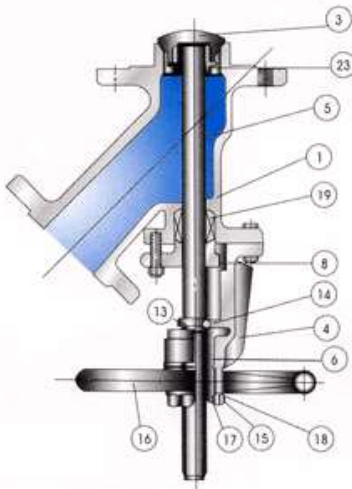

○ DIMENSION

10k-150LB

단위(mm)

SIZE	25	40	50	65	80	100	125	150	200
L	115	140	160	170	220	230	250	290	340
H	320	340	350	400	430	510	650	670	750
W	125	155	170	200	200	230	270	300	350
h	30	35	35	45	55	65	70	75	90
D	38	55	62	80	95	115	140	165	215